

HYDRAULIC TEST PRESSURE

BODY	SEAT
31 Kg/Cm ²	21 Kg/Cm ²

ALL DIMENSIONS ARE IN MM UNLESS OTHERWISE SPECIFIED

VALVE SIZE	A±3	ØD±5	ØE±2	C	D
40MM	42	82	37	45	82
50MM	45	99	47	55	88
65MM	48	120	60	63	100.5
80MM	50	133	71.5	71	109
100MM	55	159	95	82	131
125MM	57	186	121	97	155
150MM	58	212	143	109	164
200MM	66	266	189	140	201
250MM	74	326	239	172	228
300MM	83	382	290	200	267
350MM	92	432	340	223	308
400MM	102	482	388	268	334
450MM	114	522	430	286	370
500MM	127	580	482	368	402
600MM	154	695	546	400	474

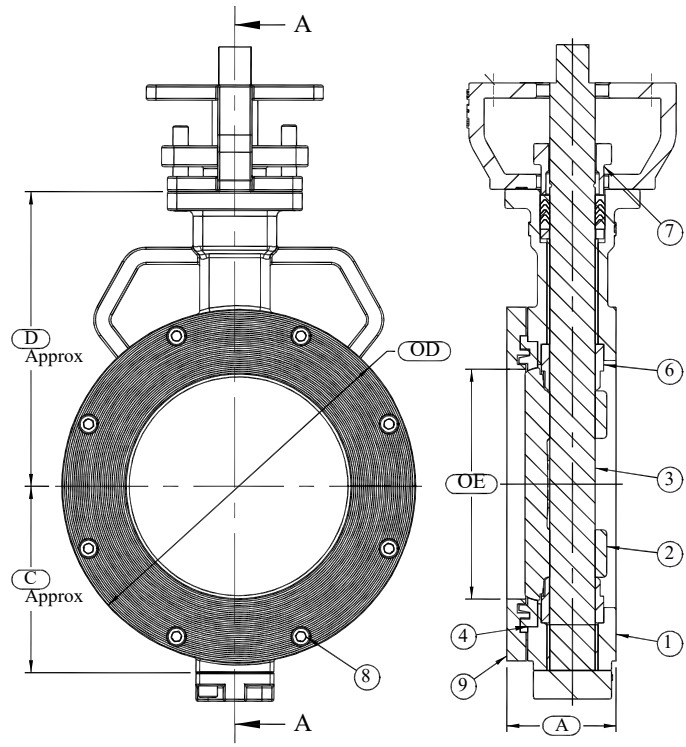

SECTION A-A

(DIMENSIONS ABOVE 600 MM AVAILABLE ON REQUEST)

APPLICABLE STANDARDS:
 DESIGN AND MANUFACTURING : API 609 / BS EN 593
 VALVE FACE TO FACE DIMENSION : API 609 CAT. B / BS EN 558
 FLANGE STANDARD CONFORMITY : ASME B16.5 150# RF
 INSPECTION & TESTING : API 598 / BS EN 12266-1

No.	Description	Material
01	Body	C.I.,WCB,CF8,CF8M,ALUMINUM
02	Disc	C.I.,WCB,CF8,CF8M,ALUMINUM
03	Shaft	S.S.410,S.S.304,S.S316
04	Seat	EPDM,NITRILE,VTION,SILICON,PTFE,GFT
05	"O"ring	EPDM
06	Bolt	S.S.304,S.S.316
07	Operation	LEVER,GEAR,PNEUMATIC,ELECTRICAL,ACTUATOR
08	Fastner	S.S.202,S.S.304
09	Retainer	M.S.,CF8,CF8M

INFO:-		 PERFECT ALLOY VALVES <small>TALUKA:-SANAND DISTRICT:-AHMEDABAD 382210</small>
SPERICAL DISC BUTTERFLY VALVE 150#		
QUOTATION.NO:-	DRN	
Tolerance:-±3mm	CHKD	
	APPD.BY	
ALL DIMENSION ARE IN M.M.	DWG NO:	PAV/BFV/PN-10/01

HYDRAULIC TEST PRESSURE

BODY	SEAT
31 Kg/Cm ²	21 Kg/Cm ²

SIZE		DIMENSIONS
INCH	MM	A
1.5"	40mm	33.5
2"	50mm	43.5
2.5"	65mm	46.0
3"	80mm	46.0
4"	100mm	52.0
5"	125mm	56.0
6"	150mm	56.0
8"	200mm	60.0
10"	250mm	60.0
12"	300mm	78.0
14"	350mm	88.0
16"	400mm	102.0

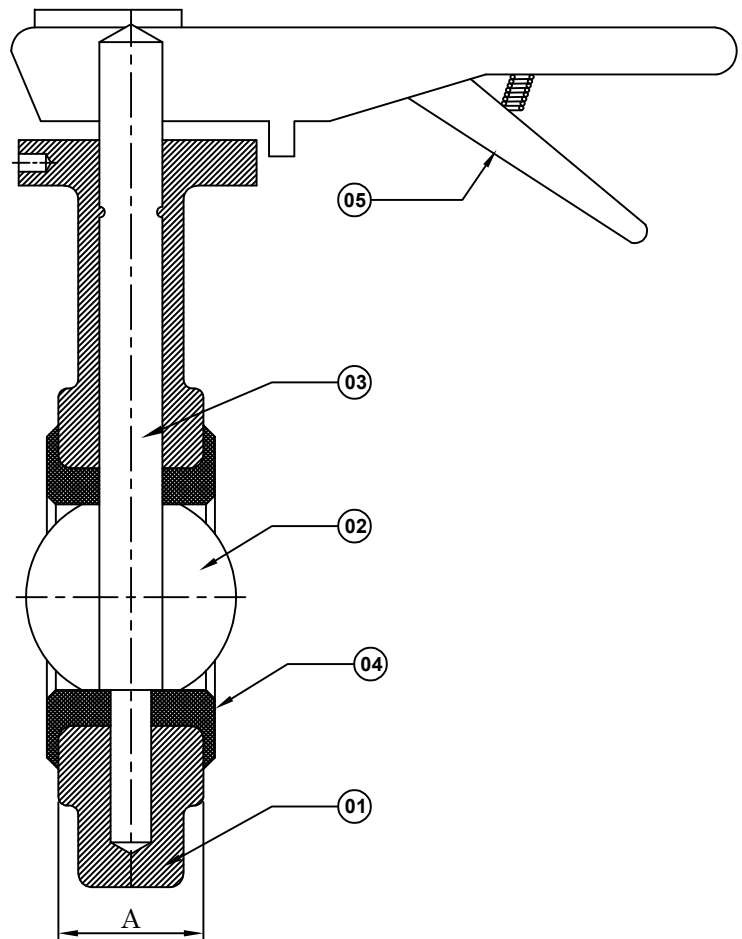

(DIMENSIONS ABOVE 400 MM AVAILABLE ON REQUEST)

TECHNICAL INFORMATION:-

DESIGNE AND MANUFACTURING : API:6D / ANSI B 16.34
 INSPECTION & TESTING : API:598
 SEAT LEAKAGE : TIGHT SHUT OFF
 PRESSURE CLASS : DN ND 10, ND 16 & ND 40 ,
 ASA 150

No.	Description	Material
01	Body	C.I, WCB, CF8, CF8M
02	Disc	C.I, WCB, CF8, CF8M
03	Shaft	S.S.410, S.S.304, S.S316
04	Seat	EPDM, NITRILE, VTION, SILICON, PTFE, GFT
05	Lever	S.S./M.S.

INFO:-		 PERFECT ALLOY VALVES <small>TALUKA:-SANAND DISTRICT:-AHMEDABAD 382210</small>
WAFER TYPE BUTTERFLY VALVE 150#		
QUOTATION.NO:-	DRN	
Tolerance:-±3mm	CHKD	
	APPD.BY	
ALL DIMENSION ARE IN M.M.	DWG NO:	PAV/BFV/150#/02

HYDRAULIC TEST PRESSURE

BODY	SEAT
15 Kg/Cm ²	10 Kg/Cm ²

DIMENSIONS

MM	F to F	THK	ØD	ØH	N	PCD
50mm	108.0	16.3	150.0	19.5	4	120.7
65mm	112.0	17.9	180.0	19.5	4	139.7
80mm	114.0	19.5	190.0	19.5	4	152.4
100mm	127.1	24.3	230.0	19.5	8	190.5
125mm	140.0	24.3	255.0	22.2	8	215.9
150mm	140.0	25.9	280.0	22.2	8	241.3
200mm	152.0	29.0	345.0	22.2	8	298.5
250mm	165.0	30.6	405.0	25.4	12	362.0
300mm	178.0	32.2	483.0	25.4	12	431.8
350mm	190.0	35.4	535.0	28.6	12	476.3
400mm	216.0	37.0	595.0	28.6	16	539.8
450mm	222.0	40.1	635.0	31.8	16	577.9
500mm	229.0	43.3	700.0	31.8	20	635.0
600mm	267.0	48.1	815.0	34.9	20	749.3

(DIMENSIONS ABOVE 600 MM AVAILABLE ON REQUEST)

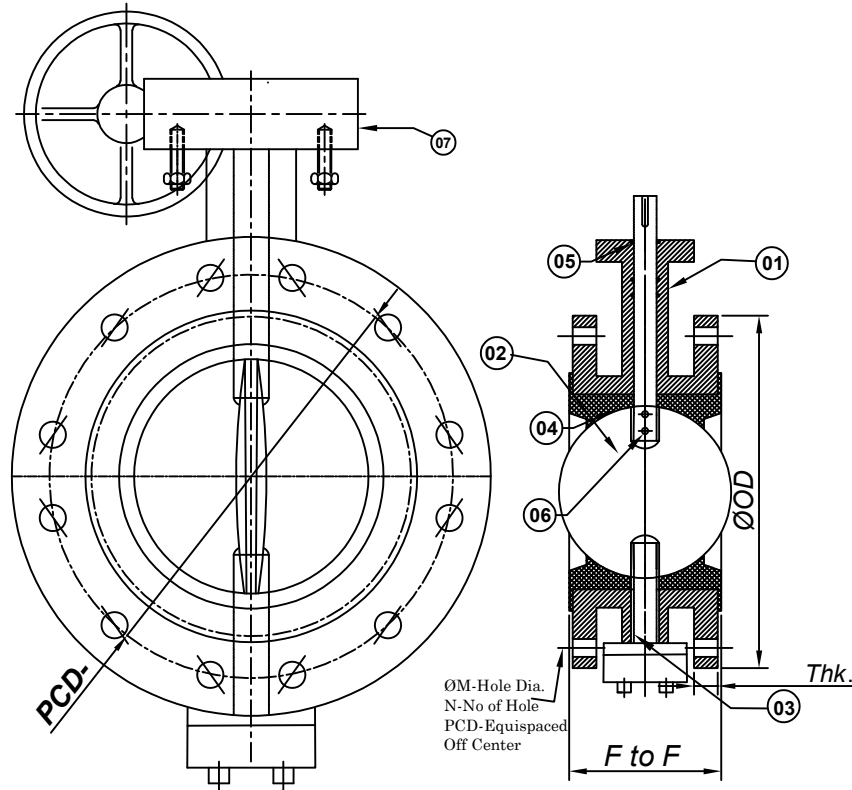

TECHNICAL INFORMATION:-

DESIGNE AND MANUFACTURING : API:609 / BS:5155
 INSPECTION & TESTING : API:598
 FLANGE STD.CONFORMITY : ASME B 16.5 FF 150#
 FACE TO FACE : API:609 / BS:5155

No.	Description	Material
01	Body	C.I.,WCB,CF8,CF8M
02	Disc	C.I.,WCB,CF8,CF8M
03	Shaft	S.S.410,S.S.304,S.S316
04	Seat	EPDM,NITRILE,VTION,SILICON,PTFE,GFT
05	"O"Ring	S.S./M.S.
06	Bolt	EPDM,NITRILE,VTION,SILICON,PTFE,GFT
07	Gear Box	Standard

INFO:-	 PERFECT ALLOY VALVES <small>TALUKA:-SANAND DISTRICT:-AHMEDABAD 382210</small>	
BUTTERFLY VALVE, FLANGED ENDS. 150#		
QUOTATION.NO:-	DRN	
Tolerance:-±3mm	CHKD	
	APPD.BY	
ALL DIMENSION ARE IN M.M.	DWG NO:	PAV/BFV/150#/FE/03